

- 1.0 GENERAL NOTES  
 1.1 ALL METRIC DIMENSIONS ARE IN BRACKETS [X. X]  
 1.2 FOR PATENT INFO: <https://www.adwpat.com>  
 2.0 DESIGN NOTES  
 3.0 MANUFACTURING/SPECIAL REQUIREMENTS  
 3.1 BUS BAR SHOWN IN VARIOUS MOUNTING CONFIGURATIONS  
 3.2 TIGHTEN ALL BOLTS SNUG TIGHT, DEFINED AS THE CONDITION OBTAINED WITH THE FULL EFFORT OF AN ASSEMBLER USING AN ORDINARY SPUD WRENCH TO BRING THE CONNECTING SURFACES INTO FIRM CONTACT  
 4.0 TEST  
 5.0 PACKAGING  
 5.1 PACKAGING SHALL MEET ANDREW REQUIREMENTS PER DOCUMENT IS-PL-3005  
 5.2 PRINTED DOCUMENT TO BE PLACED INSIDE POLYBAG AND THEN IN SHIPPING CONTAINER  
 5.3 EXTRA HARDWARE MAY BE SUPPLIED, BAGGED AND SHIPPED

REVISIONS			
REV.	DESCRIPTION	DATE	APPROVED
A	INITIAL RELEASE	HC 25FEB14	TP
B	UPDATED DRAWING FORMAT	YC1059 20NOV24	BA1025 40209301CMO

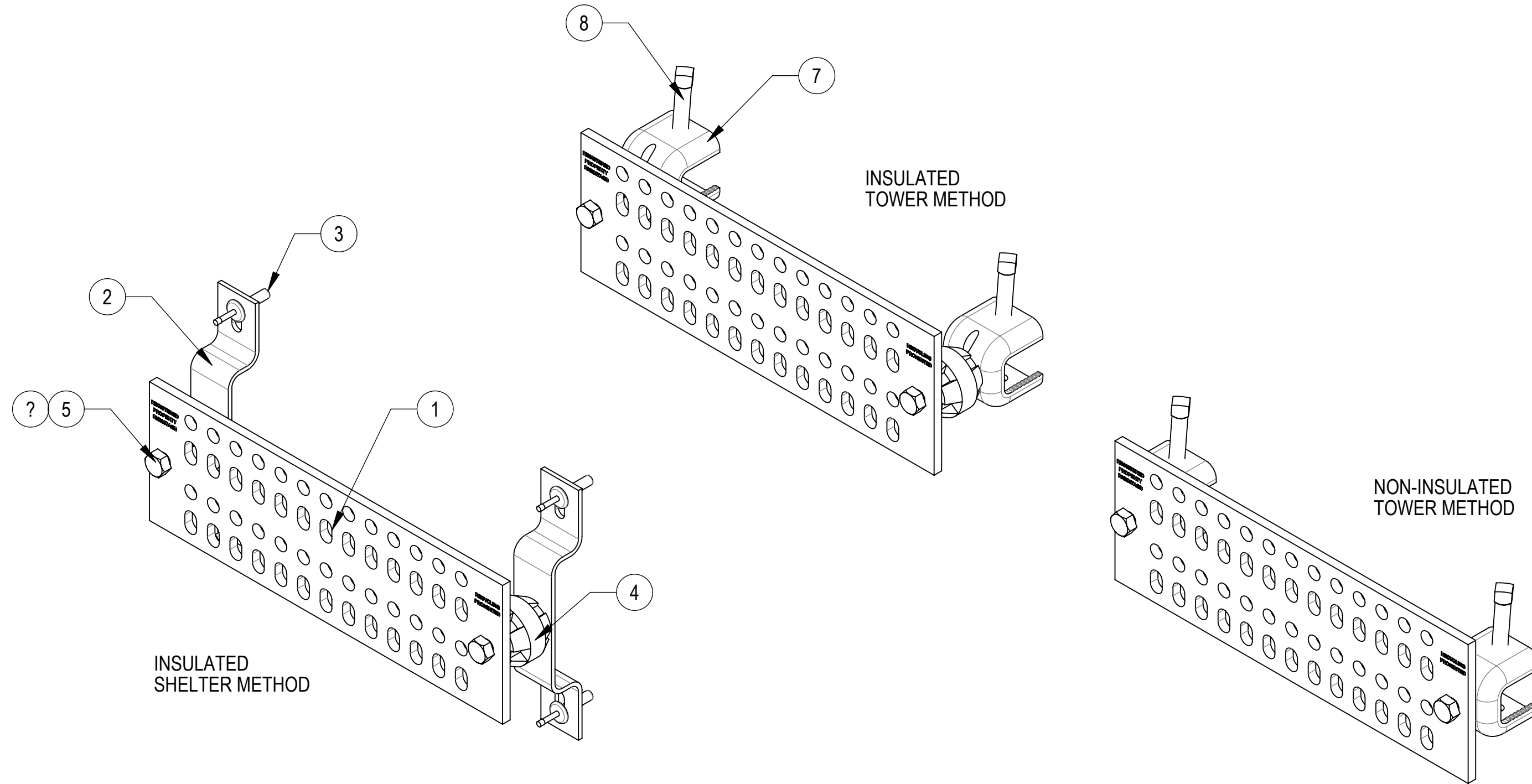

COMPONENT PART NUMBERS PROVIDED FOR ASSEMBLY PURPOSES;  
 INDIVIDUAL COMPONENTS MAY BE SHIPPED AS PARTS WITHIN AN INCLUDED KIT.

ITEM NO.	PART NUMBER	DESCRIPTION	QTY.	WEIGHT	NOTE NO.
1	CBB0412NM01	GROUND BUSS BAR 4X12	1	3.05 LBS	
2	MT500GDP	STANDOFF BRACKET	2	0.33 LBS	
3	DPA141ZP	6.5 X 25mm DRIVE PIN ANCHOR	4	0.02 LBS	
4	MT520	INSULATOR W/ 3/8" INSERT	2	0.21 LBS	
5	SB0305	3/8" X 5/8" SS BOLT	4	0.04 LBS	
7	45840G-1	HANGER CLAMP	2	0.38 LBS	
8	GB0316-4	SQUARE HEAD SET SCREW, 3/8-16X1-3/4	2	0.07 LBS	

DENSITY		lbs/in <sup>3</sup>
MASS	4.98	lbs
VOLUME	19.44	in <sup>3</sup>
SURFACE AREA	231.33	in <sup>2</sup>
HEIGHT	7.20"	
LENGTH	2.53"	
WIDTH	3.76"	

**ANDREW**® an Amphenol company

TOLERANCES		SAP MATERIAL MASTER	
1 PLACE .X[X] ± 0.12[3.0]	3 PLACE .XXX[X] ± 0.03[0.8]	<b>CBB-0412N-1MU</b>	
2 PLACE .XX[X] ± 0.06[1.5]	ANGLES ± 2°		
FINISH		MATERIAL	
UNLESS OTHERWISE SPECIFIED DIMENSIONS ARE IN INCHES INTERPRET PER ANSI Y 14.5M-1994		NAME	TITLE
		CE HC	25FEB14
		RW JL1183	07/14/2025
		AD YMENG	07/14/2025
ECN 40209301CMO		SCALE <b>1:4</b>	DOCUMENT NO. <b>CBB-0412N-1MU</b>
SIZE	Auth Group INSL	MODEL	DRAWING
<b>C</b>		VERSION 01	STATUS RE
		REVISION <b>B</b>	VERSION 01
		STATUS RE	REVISION <b>B</b>
			SHEET 1 OF 1

Confidential